



BULL5M



CONTROL PANELS:

BULL5M ——— CP.CORE p.127

AUTOMATIONS FOR SLIDING GATES RESIDENTIAL USE

with integrated control box and receiver
personalised release key
up to 500 kg



BULL.P3

Raised foundation plate included.
Floor fixing distance 260 x 117, no. 4 Ø 11,
motor fixing distance 300 x 75 no. 4

230 Vac

- Electromechanical 230 Vac geared motor with built-in control unit
- Optional encoder connection using MAG.E accessory
- The encoder device ensures crush prevention and precision in the gate moving phases
- Full metal release system
- Magnetic limit switches accessory available (MLS)

BULL5M AUTOMATIONS FOR SLIDING GATES



RI.M4F
9272010
M4 rack 30x12x1000mm slotted and galvanized. Supplied with M6 metric screws and threaded spacers.
Packaging: 4 pcs

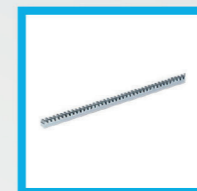

RI.M4Z
9272030
M4 galvanized rack (22x22x2000 mm).
Packaging: 2 pcs



RI.M4P
9272020
M4 Nylon rack with steel core, 28x40x1000 mm. Slotted, supplied with self-drilling screws.
Packaging: 10 pcs



MAG.E
9760021
Magnetic sensor device to detect obstacles and manage deceleration.



MLS
9387001
Magnetic limit switches for BULL. Suitable for snowy places.



SB.BULL8.F
9747025
Externally fitted anti-intrusion cable unlock device (L=4.5m).



ID.TA
9846019
Warning board.



ESA BASIC
9176108
System that reduces the electrical energy consumption.

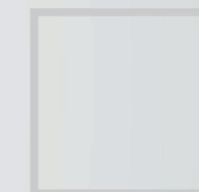
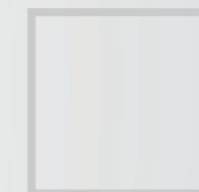
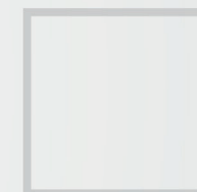

MADE IN ITALY

COMPLETE KITS

KBULL5M 9592091

- 1 **BULL5M** 230 Vac Operator with control unit and built-in receiver
- 1 **PUPILLA.F** Pair of photocells
- 1 **LAMPI.LED** 230 Vac Led flashing light with built-in aerial
- 1 **TOKEY** Metal key selector
- 1 **TO.GO2WV** 433.92 MHz Transmitter

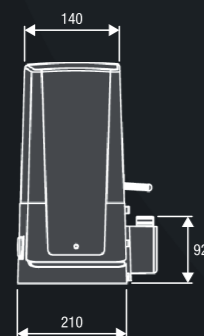
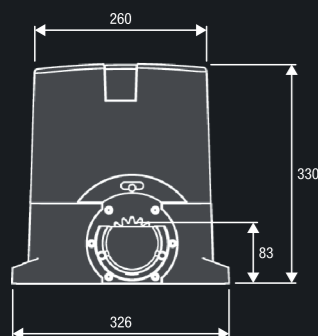

TECHNICAL DATA

	BULL5M
Code	9591434
Power supply	230 Vac (50-60Hz)
Motor supply	230 Vac
Max absorbed current	1.3 A
Max Thrust	650 N
Opening speed	10,5 m/min
Operation cycle	30%
Protection level	IP44
Operating temperature	-20°C /+50°C
Max gate weight	500 kg
Driving gear for rack	M4 Z18
Weight	10.6 kg
Items no. per pallet	36
Kits no. per pallet	30