

Outdoor Short Range Beam

OPT-AX-130TN

Compact & Durable Photoelectric Detector



Features

- 40m detection range
- Anti-frost hood cover
- Outdoor ready IP55
- Easy angle adjustment
- High grade spherical
- Adjustable beam interruption period
- 99% beam blocking stability

Features

IP65 structure with high sealing rubber packing

Rubber packing is used for all conceivable points where water or dust may penetrate, such as wiring holes, wire ports and the outer chassis. Prevention from dust, bugs and water delivers performance with higher reliability against false alarms and breakdowns.

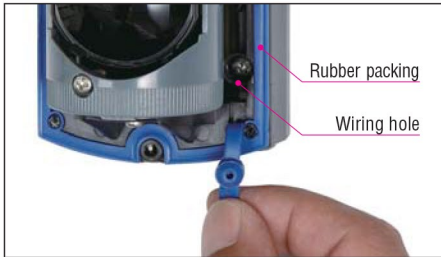

IP65
Waterproof.
Protected against water jets from any direction
Dust-tight.
No ingress of dust.
International Protection Code.
It shows the degree of protection provided by enclosures.

Anti-frost hood cover

A hood is installed to prevent frost forming on lower beams. It also makes the maintenance easy because the surface of cover is flat.

Easy angle adjustment

It allows the installer to finely adjust the beam easily.

High grade spherical lens

The high grade spherical lens creates more sharply defined and precise infrared beams compared to ordinary fresnel lenses.

99% beam blocking stability

Enables stable operation with as much as 99% loss of beam energy caused by heavy rain, dust storms, fog or snow.

A.G.C. (Automatic Gain Control) Circuit

A.G.C. circuit continually monitors for gradual changes in the signal's strength caused by changing weather conditions. It adjusts the sensitivity accordingly to maintain the proper signal level for the current environmental conditions.

Adjustable beam interruption period

The beam interruption time can be adjusted to fit any application. For example, when protecting a wall or fence, a longer interruption time will catch intruders.

Lightning protection

An improved Electro-Magnetic Interference surge absorber and high surge resistive relay has been installed to protect from lightning surges and maintain stable operation.

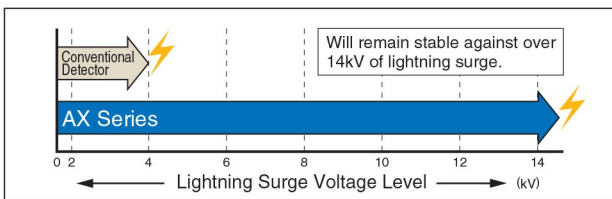

Specifications

Model	AX-130TN
Maximum detection range	40m (130ft)
Maximum arrival distance	400m (1300ft)
Detection method	Infrared beam interruption detection
Interruption period	Selectable between 50, 100, 250, 500msec (four steps)
Power supply	10.5 – 28V DC
Current consumption (Transmitter + Receiver)	41mA max.
Alarm period	2sec (±1) Nominal
Alarm output	N.C. 28V DC, 0.2A max.
Tamper switch	N.C.; open when cover is removed 28V DC, 0.2A max.
Operating temperature	-35°C – +60°C (-31°F – +140°F)
Environment humidity	95% max.
Alignment angle	± 90° Horizontal, ± 5° Vertical
Location of installation	Indoor / Outdoor : Wall / Pole Mounting
Weight (Transmitter + Receiver)	650g (22.9oz)

Dimensions

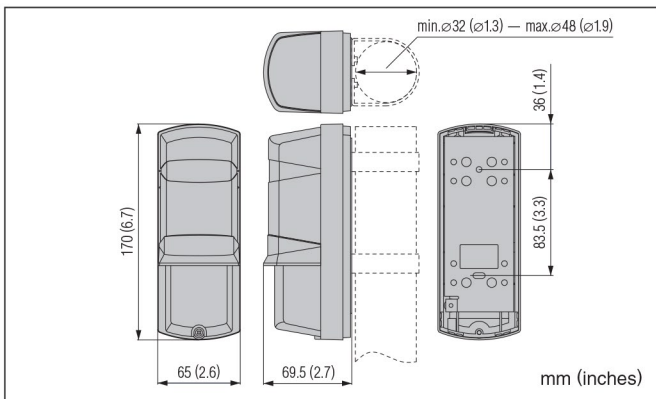

Options

- 

HU-3 : Heating Unit
 Heating unit for severe low temperature conditions
 24V DC/AC, 420mA max.
- 

BC-3 : Back Cover
 Back cover to conceal the pole.
- 

PSC-3 : Pole Side Cover
 Cover for installing 2 units to 1 pole.

