

# Swing Gate Automation

B-DU.IT24NVE

24V/DC Irreversible Eletromechanical Geared Motor

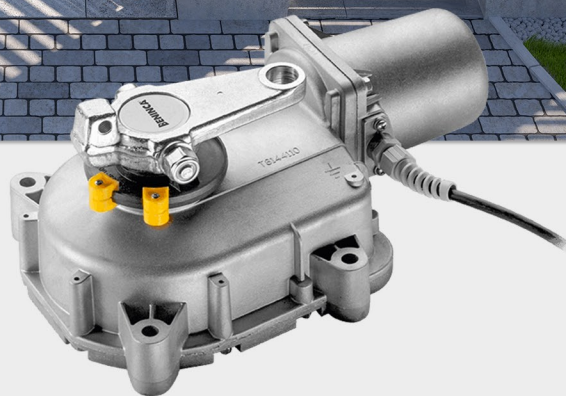

## Features

- Up to 3.5m per gate leaf
- Suitable for underground installation (IP67)
- Irreversible 24 Vdc electromechanical geared motor for intensive use, includes encoder
- The encoder device ensures maximum safety and precision in the gate moving phases
- Amperometric sensor obstacle detection system to prevent crushing
- Full metal mechanics and built-in mechanical stop



Motor supply	24 Vdc
Max absorbed current	11 A
Torque	280 Nm
Opening time	15"
Duty cycle	Intensive use
Protection level	IP67
Encoder	Yes
Operating temperature	-20°C /+50°C
Lubrication	Grease
Leaf max dimension	3.5 m
Weight	10 kg
DU.ITIX weight	8.1 kg
DU.ITCF weight	9.6 kg



**Control Unit**

B-DU.IT24NVE ——— B-BRAINY24

### Product Dimensions

