

## FMT-312E, FMT-31202E, FMT-31204E

12V 1Watt 27MHz Transmitter

### Features

- 3 versions available – 1-channel (FMT-312E), 2-channel (FMT-31202E) and 4-channel (FMT-31204E)
- 1 Watt Transmitter with current consumption of 300mA
- Long range – up to 3km
- Specially programmed micro-controller
- Durable alloy metal case



### Application

- Pump Control Units
- Long distance panic button
- On/Off applications in agricultural devices
- Security alarm systems
- Basic Telemetry eg. Water level indication

### Description

The FMT-3... series has **3 versions** - 1-channel (FMT-312E), 2-channel (FMT-31202E) and 4-channel (FMT-31204E). **No case versions** are also available - 1-channel (FMT-312), 2-channel (FMT-31202) and 4-channel (FMT-31204). The FMT-3... series has a **1-watt transmission** with a **current consumption of 300mA**.

The FMT-3... series is designed to give a controlled range of up to 3km. The controlled operation can be any electronic or electrical operated device when used with the FMR-... series of receivers.

The transmitter uses a specially programmed **micro-controller**, which ensures the highest reliability, low sleep mode current (10uA) consumption and greater flexibility.

The FMT-312 transmitter is the **PCB assembly** only, while the FMT-312E transmitter is enclosed in an alloy metal case.

**External supply connection** and **SO239 antenna socket** is provided with the transmitter.

The **transmitter modes** are user selectable by simply setting the 2-Way dip-switch on the transmitter board.

**Care should be taken not to transmit without an**



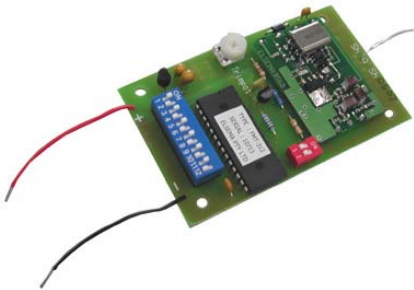
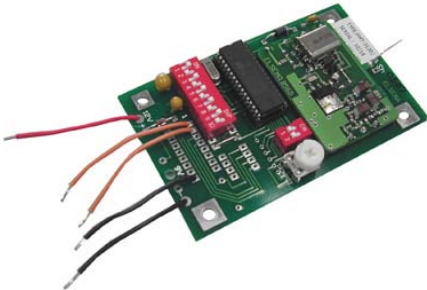
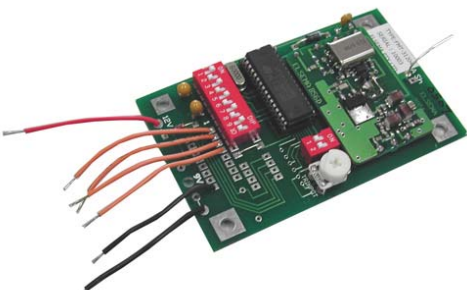

### Products in the Range

		
<p>FMT-312E – 1-channel</p>	<p>FMT-31202E – 2-channel</p>	<p>FMT-31204E – 4-channel</p>

**No Case Version**

		
<p>FMT-312 – 1-channel, no case</p>	<p>FMT-31202 – 2-channel, no case</p>	<p>FMT-31204 – 4-channel, no case</p>

**Transmitter Modes**

	<p><b><i>Off Delay 2 – 62 seconds</i></b>          Transmitter will transmit a 1.5 second transmission burst and then stop for the "off delay" time selected. The "off delay" time is user selectable between 2 to 62 seconds by adjusting trimpot on the transmitter board. If the code changes during the "off delay" period the new code will be transmitted immediately. When the "off delay" time lapses, transmitter will transmit another burst. The transmitter will cycle (transmission and off delay) indefinitely, if at least one code switch from the 12-Way code switch is ON and supply is connected.</p>
	<p><b><i>Off Delay 1 – 10 minutes</i></b>          Same as mode 1 except the "off delay" is user selectable between 1 to 10 minutes.</p>
	<p><b><i>Continuous Transmission*</i></b>          Transmitter will transmit continuously, if at least one code switch from the 12-Way code switch is ON and supply is connected. A transmission limit of five minutes is used to comply with local radio regulations.          To activate a receiver for longer than 5 minutes, use the delay off feature in the receiver (FMR-212T) and transmitter. The delay off feature in the receiver needs to be set <u>more</u> than that of the transmitter. This ensures that the transmitter keeps resetting the off delay in the receiver.</p>
	<p><b><i>1.5 – 10 seconds one burst transmission</i></b>          Transmitter will transmit one burst and then go to standby or sleep mode. Adjusting the trimpot will vary the burst length. <i>When the code is changed and supply is connected, transmitter will emit one new burst of the new code. (This only applies to FMT-312).</i> FMT-31202 and FMT-31204 will only transmit when a different input is activated.</p>
<p>Sleep mode (10 uA) is activated when all 12 code switches are OFF; this applies to all four modes.</p>	

*(Grey illustrates the position of the DIP switches)*

\* Refer to the website for further details. <http://www.elsema.com/contitrans.htm>

**Technical Data**

Power Supply	11 to 13.6 VDC (for constant RF-Output), screw type terminal. Absolute maximum 14VDC.	
Current Consumption	Nominal 300mA at 12VDC supply (Transmitting) Nominal 12mA on standby Less than 10uA on sleep mode (only when all code switches are OFF otherwise it is on standby)	
Operating Frequency	27.145MHz (Other frequencies available on 27.045, 27.195 and 27.455 MHz. The 27.455 frequency is not available for Australia).	
Carrier Frequency Tolerance	Crystal controlled, 30 parts per million (0 to 50°C).	
R.F. Output Power	1 Watt, into 50 ohms SO239 socket at 13.6VDC.	
Antenna	SO239 socket is provided. Optimum performance use Elsema ANT27L antenna	
Type Of Emission	Narrow-band-width Frequency Modulation (5K00F1D)	
Frequency Deviation Limiting	1500 Hz non-return to zero	
Modulation Frequency	1 kHz (0.96 ms/bit) (15% tolerance)	
Spurious Transmission	-13dBm (50uW)	
Necessary Band Width	±2.5 kHz	
Digital Coding System	On-board 12-way code switch Code switch is inserted into an IC socket. This is for the easy removal of the code switch. Elsema's 24W-1, 24 way ribbon cable can be inserted into the IC socket, which enables the user to have 4096 digital channels.	
Dimension	90 X 56X 15mm (PCB Assembly)	140 X 60 X 34 mm (Enclosed).
Mounting Hole Size	4.00 mm or 5/32 " (PCB Assembly)	4.76 mm or 3/16"
Mounting Hole Spacing	Length 76 mm (3.00") Width 45 mm (1.77") (PCB Assembly)	Length 125 mm (4.92") Width 45 mm (1.77") (Enclosed).
Weight	35 grams (PCB Assembly)	225 grams (Enclosed).
Useable Operating Range	Up to 3000 metres, depending on installation and type of antenna used. Recommended Antenna is Elsema ANT27L	
Compatible Receivers	All Elsema type FMR-... series	

**Using FMT-31202 and FMT-31204**

To Use FMT-31202 with a 2 channel receiver, and FMT-31204 with a 4 channel receiver, just match the 10 way dip switch on the transmitter to the receiver.

**Using 2 Different Receivers with FMT-31202**

FMT-31202 can also be used with 2 different single channel receivers e.g. FMR-212.

Make sure the 10 way dip switch on the transmitter board matches the first 10 dip switches on the receiver. Set the receivers dip switch 11 and 12 as described below.

When **Button A** is pressed, dip Switch 11 is transmitted as “**ON**” (Dip switch 11 on the Receiver is up)  
 When **Button B** is pressed, dip Switch 11 is transmitted as “**OFF**” (Dip switch 11 on the Receiver is down)

When **wire link** is connected (Factory default), dip switch 12 is “**ON**” (Dip switch 12 on the Receiver is up)  
 When **wire link** is disconnected (cut), dip switch 12 is “**OFF**” (Dip switch 12 on the Receiver is down).  
*(see picture below for the location of the wire link)*



Make sure the 10 DIP switches of the transmitter board matches the first 10 DIP switches of the receiver. Set the receivers dip switch 11 and 12 as described above.

**Using 4 Different Receivers with FMT-31204/ FMT-31204E**

FMT-31204/ FMT-31204E can also be used with 4 different single channel receivers eg. FMR-212. This can be setup as follows:

1. Make sure the 10 way dip switch on the transmitter board matches the first 10 dip switches of the receiver.
2. The receivers dip switch 11 and 12 configuration is illustrated below.



**Wiring Diagrams**

**FMT-312E**

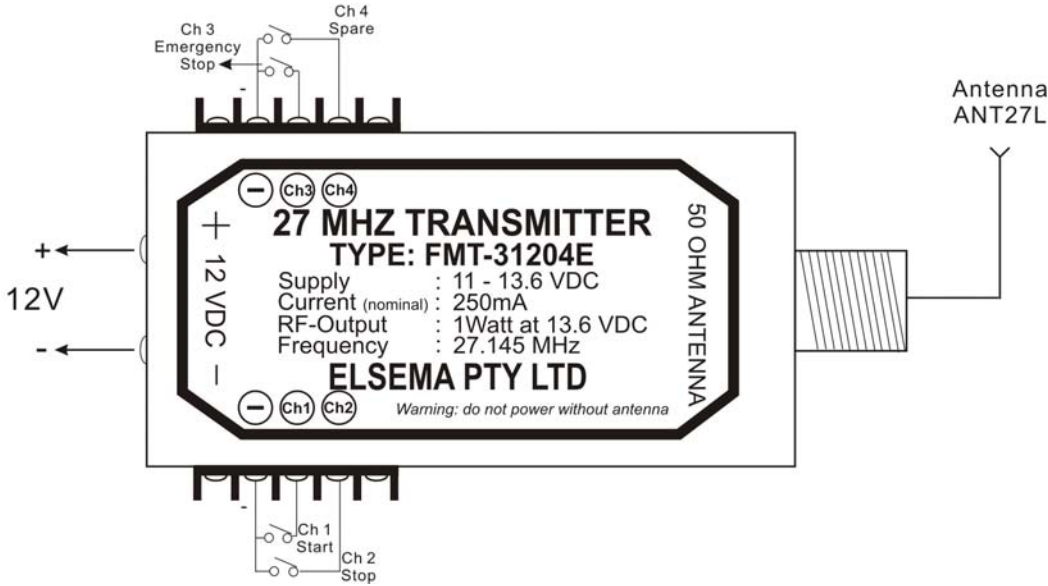
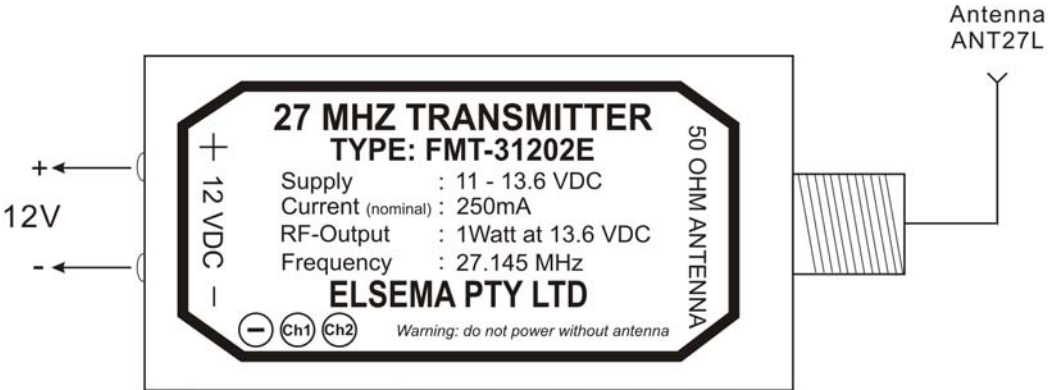
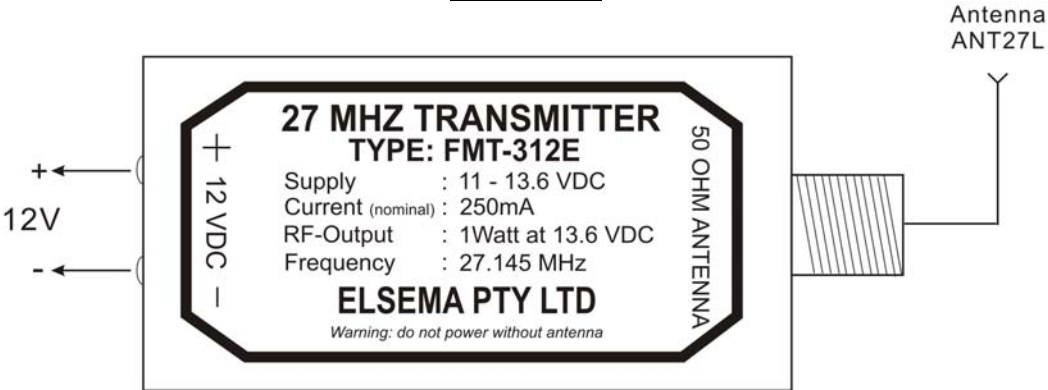

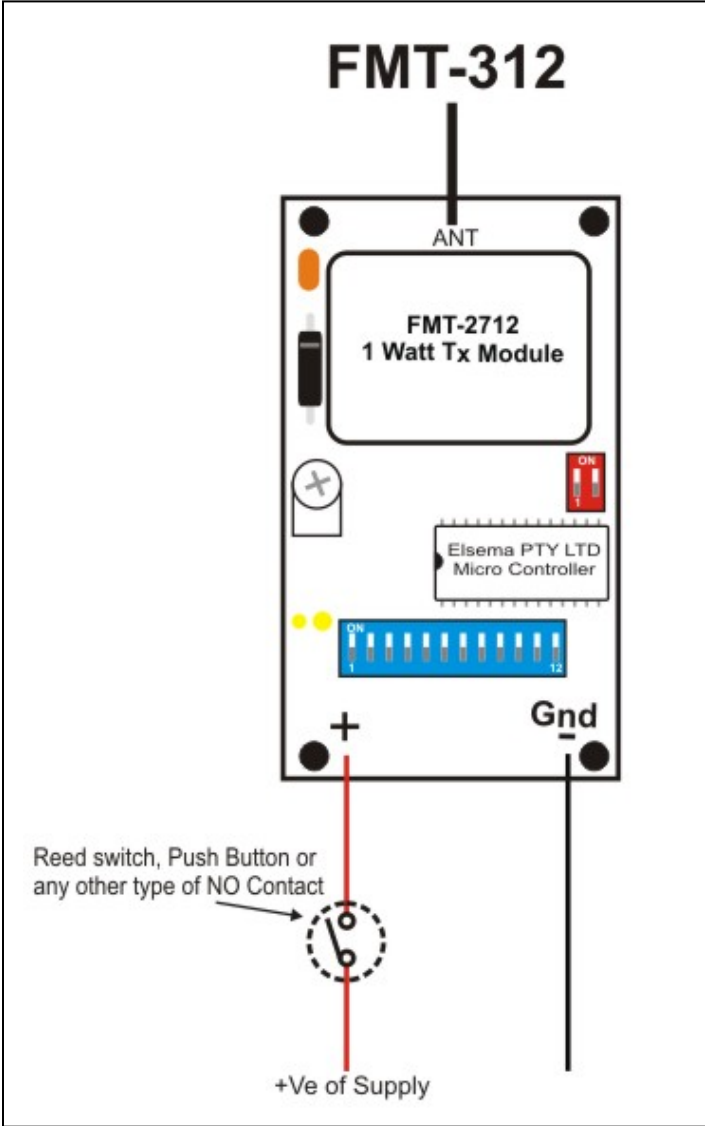

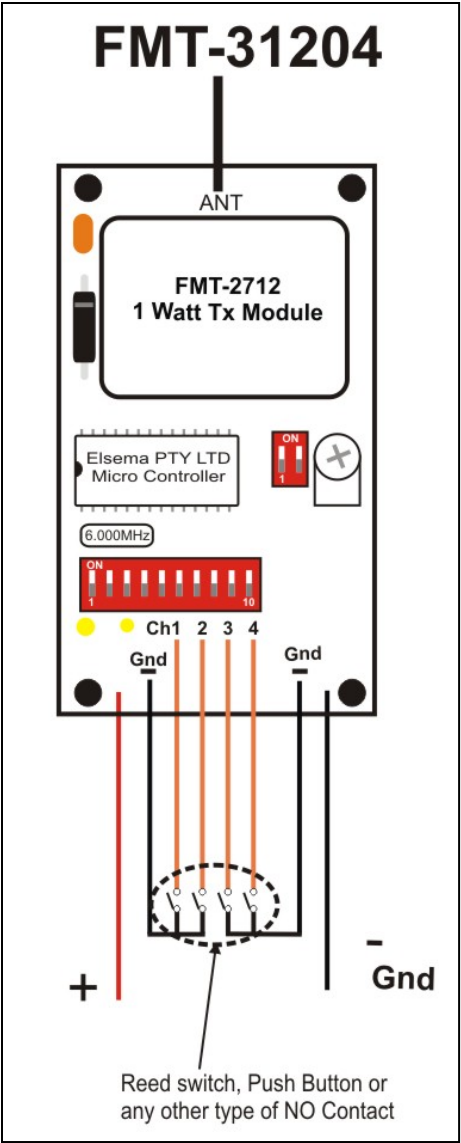
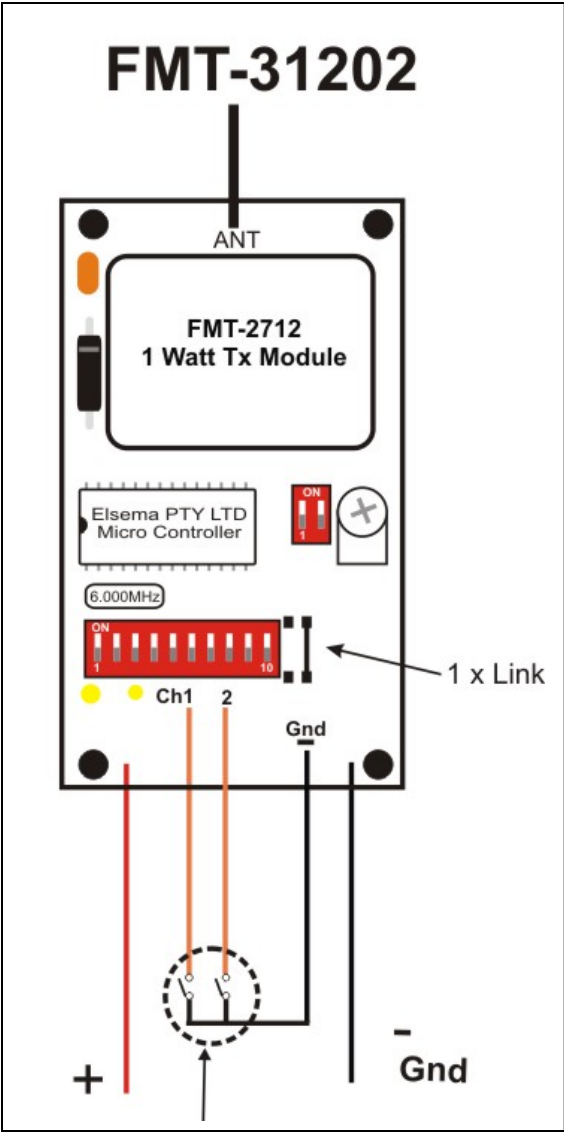

**Manufactured by**

**Elsema Pty Ltd**  
3/10 Hume Rd, Smithfield  
NSW 2164  
Ph: 02 9609 4668  
Fax: 02 9725 2663  
Website: <http://www.elsema.com>

**Distributed by**

