

CAB

MORE THAN AUTOMATION

HYDRO Industrial Use

For swinging gates up to 5 m (max. 500 kg)



www.aap.co.nz



PLUS



Silent operation and fluid movement guaranteed by the presence of the hydraulic slow-down function.



The presence of the rear joint with pin and of the adjustable spherical front joint facilitates installation operations, allowing correct operation even on gates that are not perfectly aligned.

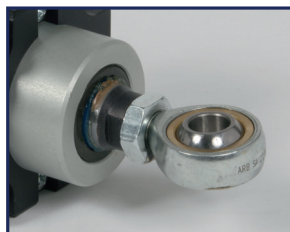

Adjustable front joint allowing stroke regulation.

HD.50

Slow reversible hydraulic operator, for gates up to 5 m, rear and front joint, with hydraulic slow-down function.

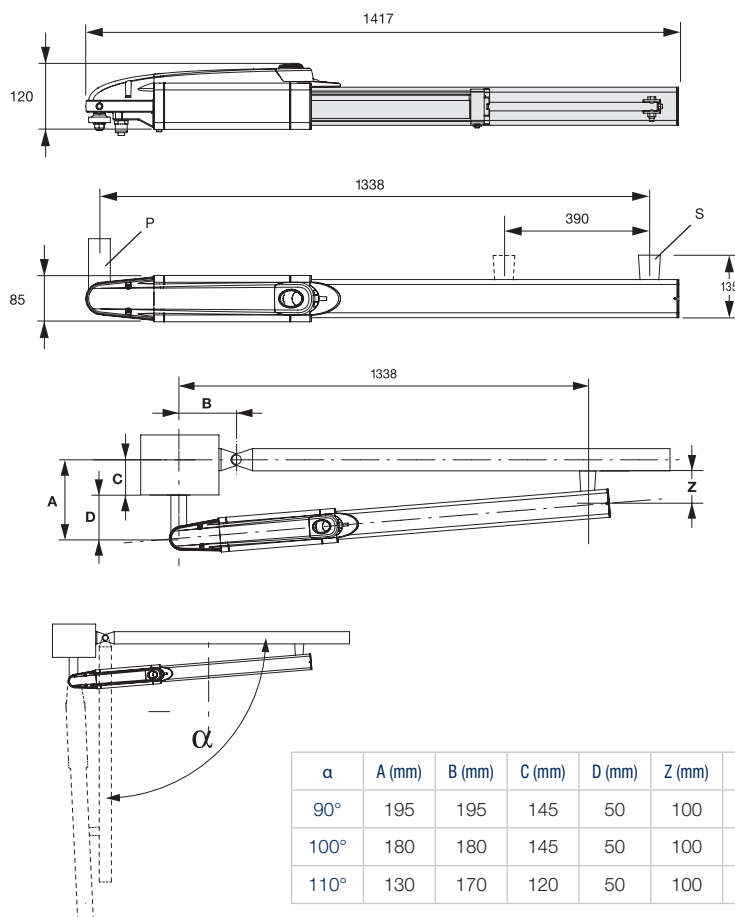

TECHNICAL DATA

Power supply	230Vac (50-60Hz)
Absorbed current	1,2 A
Absorbed power	250 W
Pump delivery	0,75 l/min
Thrust	4200 N
Stroke length	390 mm
Max. oil pressure	30 Bar
Degree of protection	IP 55
Operation cycle	INTENSIVE USE
Overload cut-out	150°C
Operating temperature	-20° C / 70° C
Ram speed	1 cm/s
Ram shaft diameter	20 mm
Opening block	YES
Closing block	YES
Hydraulic slow-down	In Closing
Joints	Front and Rear
Door leaf width	5 m
Door leaf weight	500 kg
Needs an electric lock	NO*

* For leaves of length more than 1,8 m it is suggested to install one electric lock also in the irreversible models

NB: Versions with special voltages on request